

BASIC SWITCHING CONTROL TERMINOLOGY AND INFORMATION GUIDE

LOW VOLTAGE MODULAR SWITCH (RECESSED WALL INSTALLATION)

Available with drapery motors only. A specially designed three button switch, open-stop-close, which allows direction reversal at any point. Low voltage switching connections are made, using RJ-11 modular cable, from the switching port of the motor to a modular wall jack (phone type); then inside the wall to the junction box containing the switch. Power to the motor is supplied by a 9 foot power cord.

HARD WIRED (HW)

All motors (except drapery motors and Model 9700) come with a 4 wire, 6 foot pigtail, consisting of a common, two directional wires and a ground. Used for wiring to a powered, SPDT (single-pole, double-throw) 110VAC switch. The motor's pigtail is connected either by hard wiring or by plug/receptacle to an individual junction box. If more than one motor is controlled by a single switch, isolation (parallel) relays are required.

HARD WIRED WITH ISOLATION RELAYS (HW/ISO)

This variation of Hard Wiring is used when controlling two or more motors simultaneously from a single SPDT switch. Each motor pigtail (with relay incorporated) is connected either by hard wiring or by plug/receptacle to an individual junction box. The wiring from each junction box is connected from one to the next; with the wiring from the terminal junction box going to the switch.

RADIO FREQUENCY WIRELESS REMOTE CONTROL (TI-RF)

A radio frequency controlled system for Models 140-S, 400, 9600, 9300, 5100 and 8000 systems. The receiver is built-in for Models 140-S, 9600 and 8000. The maximum range is 100'. The style of the Ti transmitters are sleek with an anti-scratch white piano lacquer finish. The Ti transmitters are available in 1, 2, 6 and 16 channels. Each transmitter includes a wall bracket. The TiWMT is a wireless wall switch with removable transmitter available in 1, 2 and 6 channels. Fully compatible with Bond Controls.

RADIO FREQUENCY WIRELESS REMOTE CONTROL (RTS)

Radio Technology Somfy, provides a comprehensive method for radio frequency control of motorized systems, with cross platform control system integration. Available both as stand alone, single motor RF control, or as an integrated part of a whole house automated system.

RECHARGEABLE BATTERY SYSTEMS

No outlet required and eliminates any electrical work. This type of motor has a built-in battery that lasts up to a year before requiring a recharge. The plug-in charger includes a 14 ft. cord. Systems available up to 144" and 26 pounds. Compatible with all RTS controls.

CONTROL SYSTEM

Provides an interface with a home theater, multi-room control system, or whole-house automation system. For drapery motors interfacing with a home theater, multi-room control system, or whole-house automation system; two (2) momentary dry contacts (switching contacts with no voltage inputted) are required for open-stop-close (two button) operation. Operation initiates with either the "Open" or "Close" contact, and a second action with either contact produces the "Stop" function. For Model 140-S, close the open/close contacts simultaneously for the stop function. All other motors (except model 9700) use two (2) momentary dry contacts. All motors are fully compatible with control systems by AMX, Control4, Crestron Electronics, Lutron Electronics, Savant, Vantage, and others.

RTS® - RADIO TECHNOLOGY SOMFY

Radio Technology Somfy (RTS) is a secure radio control system for the residential, commercial and hospitality markets. It offers a high performance, reliable and convenient wireless solution for motorization and automation, significantly reducing the wiring requirements. Wireless controls mean fast, easy installation with minimal impact on the building structure.

With the exclusive SMA-RTS receiver, the RTS control platform now extends across the entire spectrum of our product line, and is available for every drapery, blind and shade application.



Situ 1 RTS



Situ 5 RTS



Telis 16 Channel Transmitter



Telis 1 Chronis Timer Pure



DecoFlex 1- 5 Channels Wireless Wall Switch (shown: 5 channel)



Universal Interface



Repeater



SMA-RTS Drapery Motor Receiver



Dry Contact Interface (RTS)



TaHoma

BASIC ELECTRICAL WIRING INFORMATION AND DIAGRAMS FOR MODELS 5100, 8000, 9600 AND 9300 SERIES

HARD WIRING (HW)

All motors come with a 4 wire 18 gauge grounded pigtail. This consists of a neutral, two directional wires, and a ground. This type of wiring is used when the motor is to be controlled by a recessed wall switch. The pigtail is connected by either hard wiring or a plug/receptacle. A single motor is controlled by an SPDT (single pole, double throw) switch. Two motors can be controlled together by a DPDT (double pole, double throw) switch. When more than two motors are to be controlled by a single switch, isolation (parallel) relays are required for each motor.

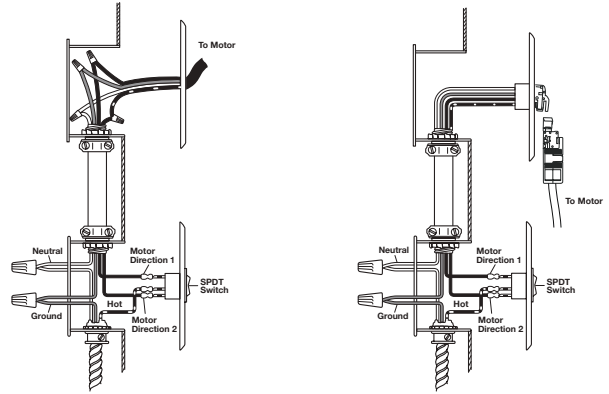

Standard Hard wiring

Hard wiring with optional plug/receptacle

HARD WIRING WITH ISOLATION (PARALLEL) RELAYS (HW/ISO)

This variation of hard wiring is used when controlling two or more motors simultaneously from a single SPDT switch. Each motor's pigtail (with relay incorporated) is connected either by hard wiring or by plug/receptacle to an individual junction box. The wiring from each junction box is connected from one to the next; with the wiring from the terminal junction box being connected to the switch.

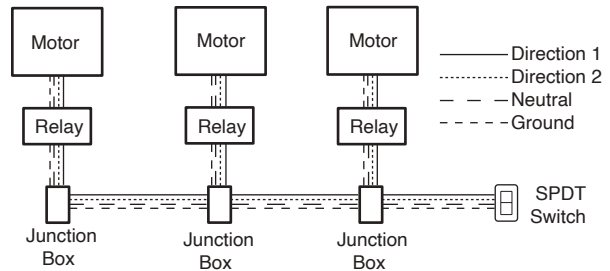

TI-RF WIRELESS REMOTE CONTROL

A radio frequency system which can be controlled by either a hand held transmitter or wireless wall switch, or both. Transmitters control from 1 up to 16 motors, with individual, group and subgroup operation options. The TiWMT is a wireless wall switch with a removable hand held transmitter in either 1, 2 or 6 channels. The maximum range is 100'. We recommend use of a Surge Protected 110 VAC duplex outlet.

RTS-RF WIRELESS REMOTE CONTROL

Radio Technology Somfy, provides a comprehensive method for radio frequency control of motorized systems, with cross platform control system integration. Available both as stand alone, single motor RF control, or as an integrated part of a whole house automated system. We recommend use of a Surge Protected 110 VAC duplex outlet.

Electrical wiring required for either Ti-RF or RTS wireless remote control, is a standard 110 VAC duplex electrical outlet. Recommend surge protection.



CONTROL SYSTEM INTERFACE

When interfacing with a home theater, multi-room control system, or whole-house automation system; two (2) momentary dry contacts (switching contacts with no voltage inputted) are required.

SWITCH AND TRANSMITTER OPTIONS FOR MODELS 5100, 8000, 9600 AND 9300 SERIES

WALL SWITCHES

S-DEC2 Almond



S-DEC1 Ivory



S-DEC3 White



S-DEC5



RADIO FREQUENCY REMOTE CONTROL (TI-RF)

Ti-1



Ti-2



Ti-6



Ti-16



Sidekick



Bond Bridge Pro



Ti-Hub
App Control



TiWMT - 1, 2, 6



ELECTRICAL/ELECTRONIC CONTROL AND WIRING LEGEND

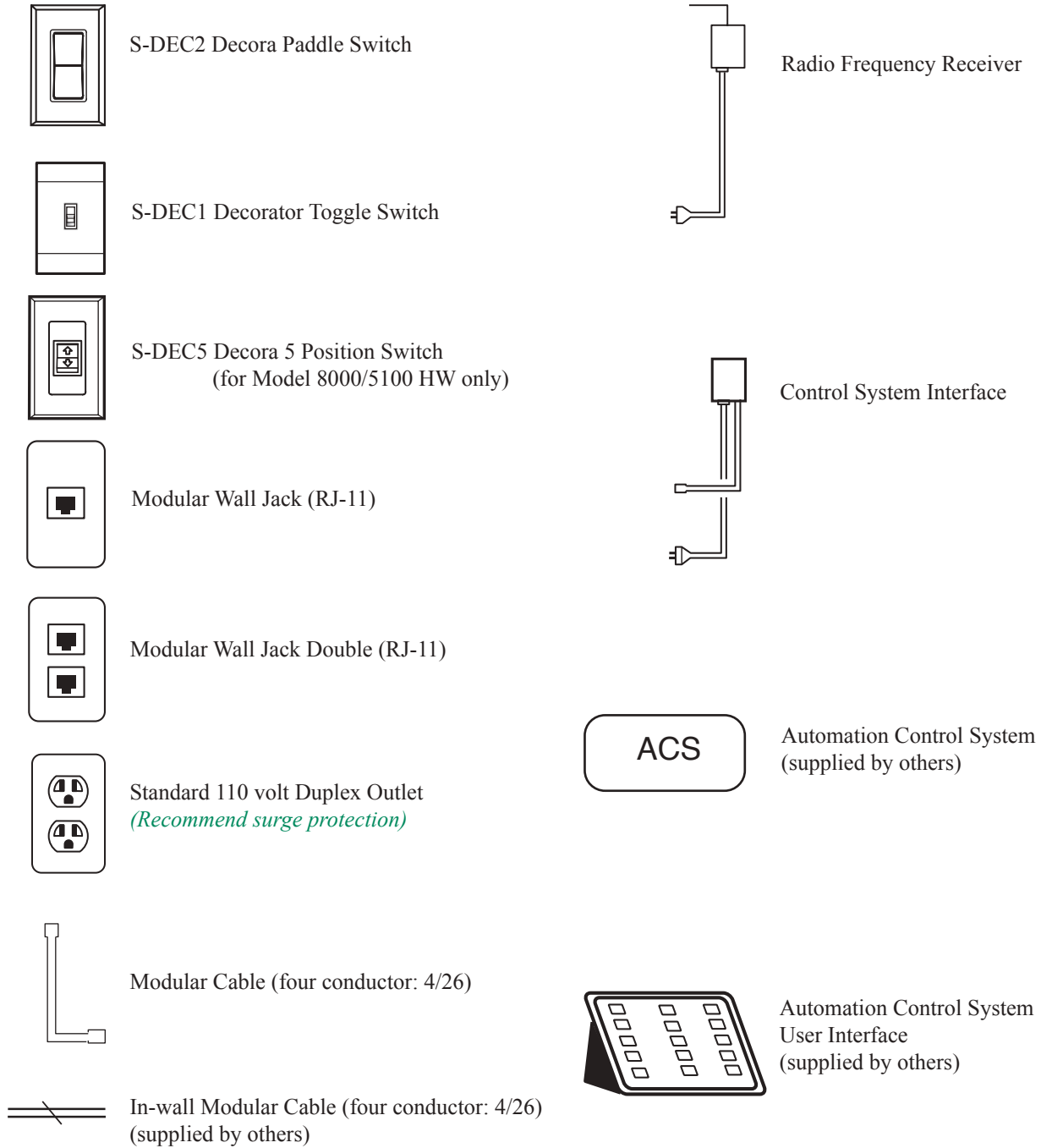

ELECTRICAL WIRING DIAGRAMS FOR MODELS 5100, 8000, 9600 AND 9300 SERIES

Recommend use of a Surge Protected 110 VAC duplex outlet.

A. Hard wired Individual SPDT Control

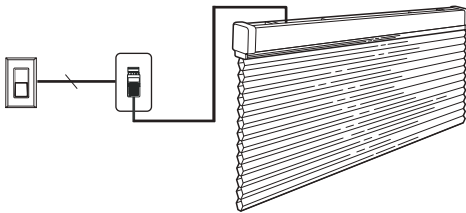

Optional Hard wiring Plug and Receptacle (PR)

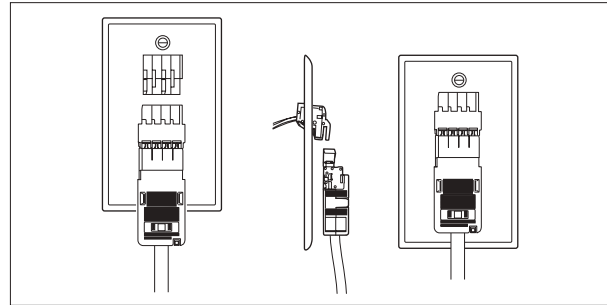

B. Hard wired Group Control using Isolation (parallel) relays

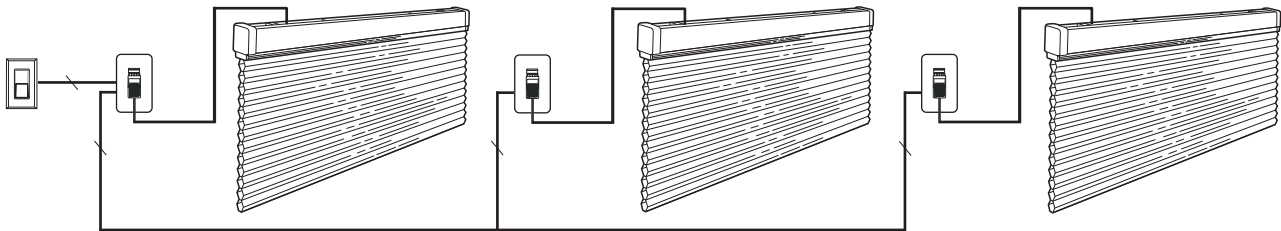

C. Individual Radio Frequency Remote Control

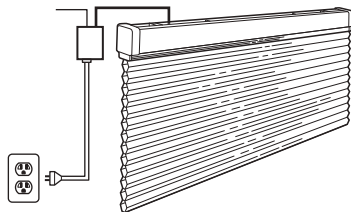

D. Individual Radio Frequency Remote Control with SPDT switch

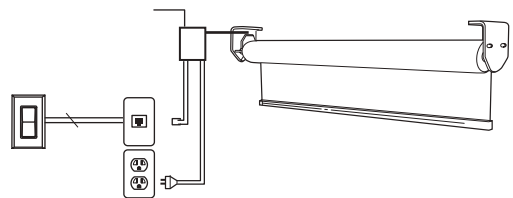

Remote control receivers, relays and low voltage interfaces, are located inside the head rails on models 9600 and 8000; and are external on models 5100 and 9300 series motors. Receiver built-in on Models 9300 RTS series motors.

ELECTRICAL WIRING DIAGRAMS FOR MODELS 5100, 8000, 9600 AND 9300 SERIES

E. Automation Control System

Recommend use of a Surge Protected 110 VAC duplex outlet.

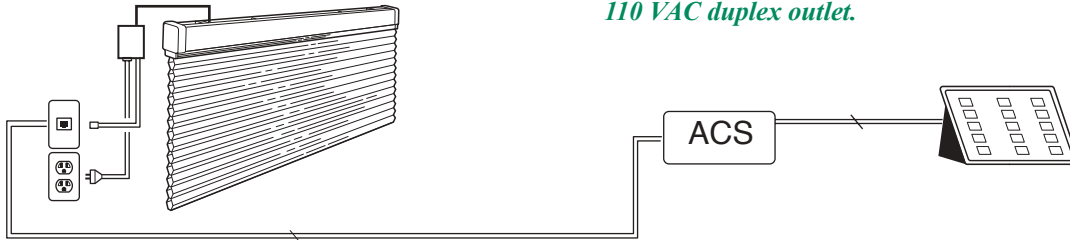

F. Automation Control System with SPDT Switch

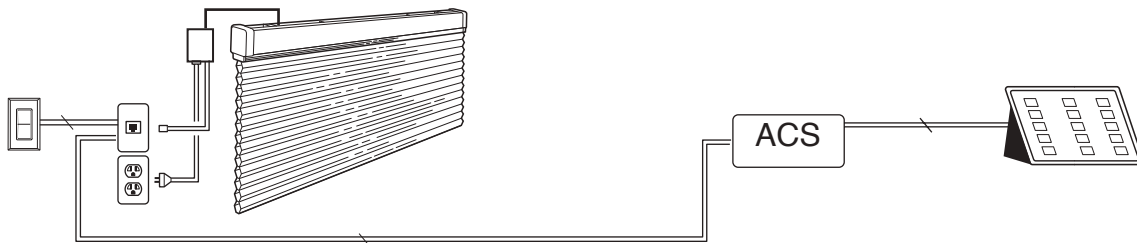

G. Automation Control System with Radio Frequency Remote Control



H. Automation Control System with Radio Frequency Remote Control and SPDT Switch

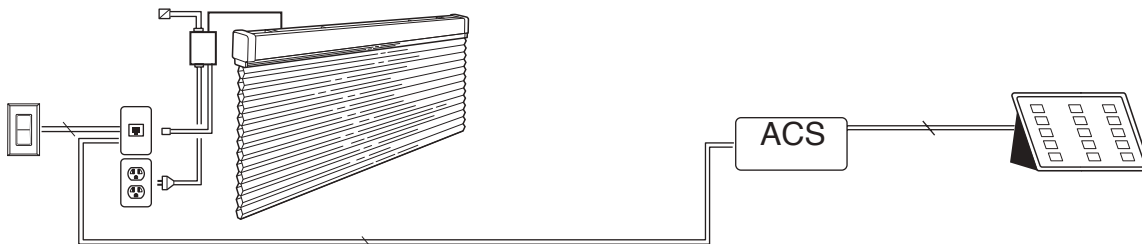

I. Modular Wiring for Automation Control System

Modular RJ-11 Plug Connection

- Yellow - Down Direction
- Green - Common (common to Yellow)
- Red - Up Direction
- Black - Common (common to Red)

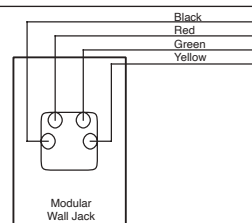
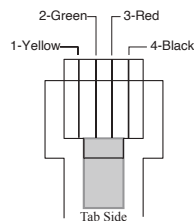

SMA-RF remote control receivers, relays and low voltage interfaces, are located inside the head rails on models 9600 and 8000; and are external on models 5100 and 9300 series motors (except 9300-RTS).

ELECTRICAL WIRING DIAGRAMS FOR MODELS 5100, 8000, 9600 AND 9300 SERIES

*Recommend use of a Surge Protected
110 VAC duplex outlet.*

J. Model 9300 series motor and Drapery Motor, with Automation Control System and SPDT Switch

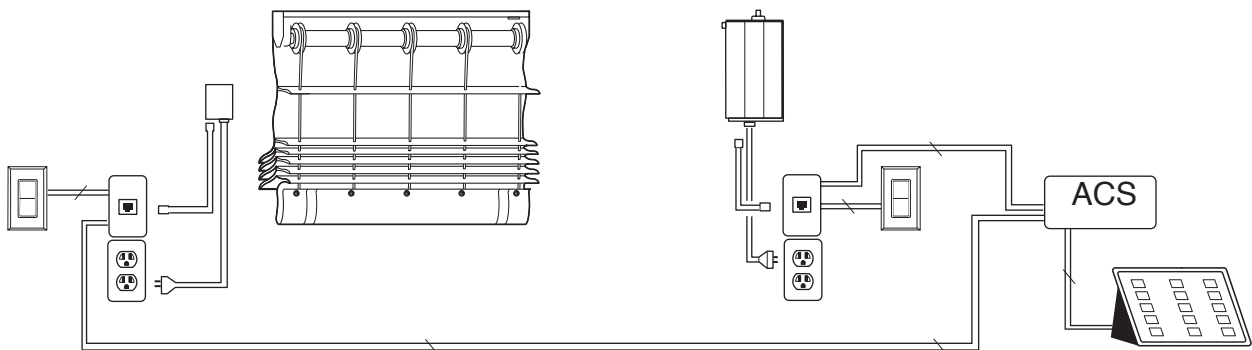

IMPORTANT INFORMATION REGARDING RADIO FREQUENCY INTERFERENCE

All radio frequency (RF) wireless remote control systems are subject to radio wave interference. When present, RF interference may be constant or intermittent.

According to FCC regulation, equipment used for RF wireless remote controlled window treatments, must follow these guidelines:

“Operation is subject to the following two conditions: (1) This device may not cause harmful interference and (2) this device must accept any interference that may be received, including interference that may cause undesired operation.”

ELECTRICAL WIRING INFORMATION AND DIAGRAMS - A COMPARATIVE GUIDE FOR CONTROL SYSTEMS

ROMAN AND ROLLER SHADES

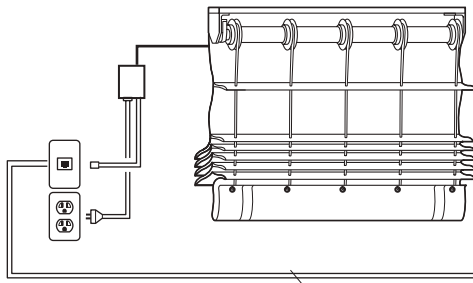

When interfacing with a home theater, multi-room control system, or whole-house automation system; two (2) momentary dry contacts are required. Operation initiates with either the “Open” or “Close” contact, and a second action with either contact produces the “Stop” function.

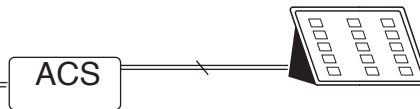

CELLULAR SHADES

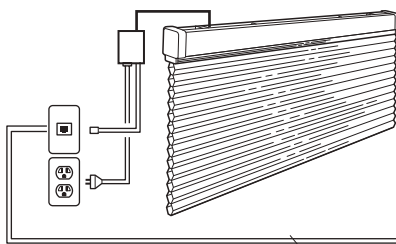

When interfacing with a home theater, multi-room control system, or whole-house automation system; two (2) momentary dry contacts are required. Operation initiates with either the “Open” or “Close” contact, and a second action with either contact produces the “Stop” function.

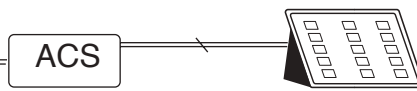

HORIZONTAL AND VERTICAL BLINDS

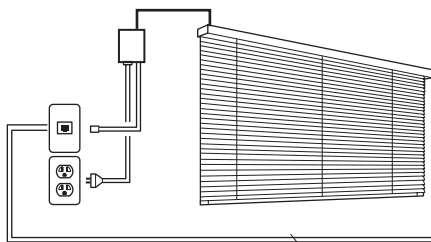

When interfacing with a home theater, multi-room control system, or whole-house automation system; two momentary dry contacts are required. “Tilting” function must have timed contacts of *less* than 1.5 seconds. “Lifting” function must have a timed contact of *more* than 1.5 seconds.

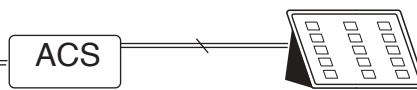

Recommend use of a Surge Protected 110 VAC duplex outlet.

Modular Wiring for Shades and Blinds Connecting to an Automation Control System

